

# Z300

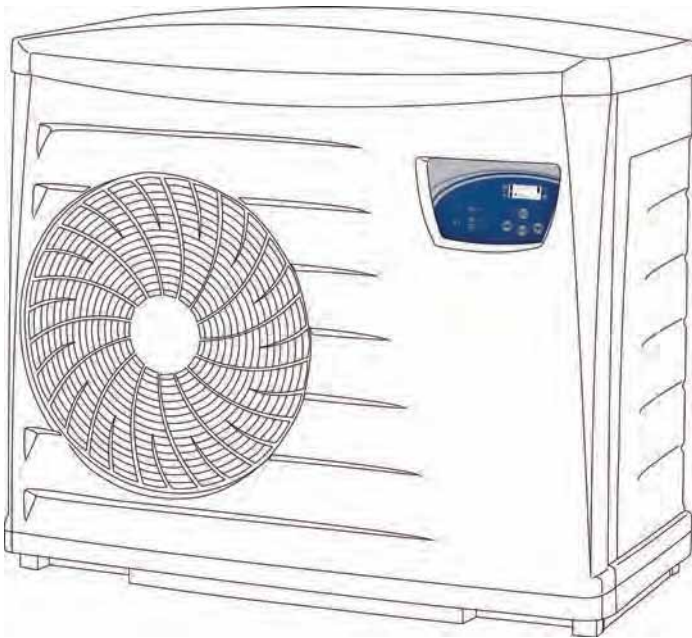

Instructions for installation and use  
English

EN



## Rainbow Pool Products

PO Box 2388, Mansfield Qld 4122

Telephone STD 61-7-3849 5385



Facsimile STD 61-7-3849 5384

Email: [info@rainbowpoolproducts.com.au](mailto:info@rainbowpoolproducts.com.au)

Web: [www.rainbowpoolproducts.com.au](http://www.rainbowpoolproducts.com.au)

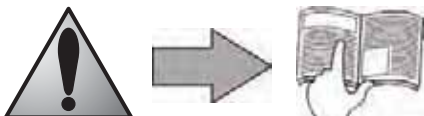
More languages on:  
[www.zodiac-poolcare.com](http://www.zodiac-poolcare.com)



- Read this manual carefully before installing, maintaining, or repairing this device!
- The symbol  indicates important information that must be taken into account in order to avoid risk of personal injury and/or damage to the appliance.
- The symbol  indicates useful information.



## Warnings

- Our products may be subject to change without notice as part of our continuous improvement policy.
- Exclusive use: pool water heating (must not be used for any other purpose).
- The device must be installed by a qualified technician according to the manufacturer's instructions and in compliance with local regulations. The installer is responsible for the correct installation of the device and for ensuring compliance with local regulations. The manufacturer shall not be held liable for any potential issues that may occur as a result of failure to comply with local standards pertaining to installation.
- This appliance must be handled by competent and qualified personnel (physically and mentally) who are familiar with the operating instructions (by reading the user guide). Individuals who do not satisfy these requirements must not handle the device so as to avoid exposure to potentially dangerous parts.
- In the case of device malfunction: do not attempt to repair the device yourself, call your installer.
- Before carrying out any operation on the device, ensure that the power supply is off, that the device is decommissioned, and that the "heating priority" function is de-activated.
- Before reconnecting any component, check that the voltage indicated on the device corresponds to the mains voltage.
- If any safety device is removed or shunted, the warranty will automatically be void. This will also apply if parts are replaced with parts acquired elsewhere than in our stores.
- Do not vent R410A fluid into the atmosphere: R410A is a fluorinated greenhouse gas that is covered by the Kyoto Protocol, with a Global Warming Potential (GWP) = 1975 - (see regulation on fluorinated greenhouse gases, European Community Directive EC 842/2006).
- Incorrect installation may cause serious damage and/or personal injuries (potentially death).
- Keep the device out of the reach of children.
- This heat pump is compatible with all types of water treatment systems.



# Summary

<b>1. Information before installation .....</b>	<b>2</b>
1.1 General terms of delivery, storage and transport .....	2
1.2 Content .....	2
1.3 Operating conditions .....	3
1.4 Technical specifications .....	3
<b>2. Installation.....</b>	<b>3</b>
2.1 Access to the technical compartment .....	3
2.2 Selecting an installation site .....	3
2.3 Installing the device .....	4
2.4 Hydraulic connections.....	4
2.5 Electrical connections .....	5
<b>3. Use .....</b>	<b>7</b>
3.1 Presentation of the regulation.....	7
3.2 Starting the device .....	8
3.3 Checks to perform after start-up .....	8
3.4 Winter storage .....	9
<b>4. Maintenance.....</b>	<b>9</b>
4.1 Maintenance instructions .....	9
4.2 Additional recommendations .....	9
4.3 Available accessories .....	10
4.4 Recycling .....	10
<b>5. Troubleshooting .....</b>	<b>10</b>
5.1 Display of the regulator .....	10
5.2 Solving malfunctions .....	12
5.3 FAQ.....	12
<b>6. Product registration .....</b>	<b>13</b>

Information included at the end of the manual:



- wiring diagrams
- dimensions
- description
- compliance certificate

## 1. Information before installation





### 1.1 General terms of delivery, storage and transport

Any equipment, even shipping and packing free, travels at the consignee's risk. If any damage caused during transport is identified, the consignee should make any reservations in writing on the carrier's bill of lading (confirmation to be sent to the carrier within 48 hours by registered mail with acknowledgement of receipt).

**The device must be transported and stored upright on its pallet in its original packaging.**

If the device has been turned on its side, this should be mentioned in the reservations made in writing to the carrier.

### 1.2 Content

			
X1	X2	X2	X1
in a bag in the technical compartment, see §2.1			

## 1.3 Operating conditions

Operating range:

- air temperature of between 5 °C and 38 °C for standard models,
- air temperature of between -8 °C and 38 °C for D models,
- water temperature of between 10 °C and 32 °C,



Maximum temperature of 32°C to protect the pool liner.

The D version also features a de-icing function by using forced ventilation or reversed cycle.

## 1.4 Technical specifications

Z300	Voltage	Power input*	Power output*	Nominal current input*	COP*
		kW	kW	A	
M4	230V-50Hz	1.7	7.6	7.9	4.5
M5	230V-50Hz	2.2	10.4	10.3	4.7
T5	400V-50Hz	2.2	10.5	4.25	4.8
M7	230V-50Hz	2.88	13.9	13	4.8
MD5	230V-50Hz	2.2	10.7	10	4.9
TD5	400V-50Hz	2.2	10.5	4.4	4.8
MD8	230V-50Hz	3.6	15.7	16	4.5
TD8	400V-50Hz	3.6	15.7	7.4	4.5

\* with ambient air at +15 °C, pool water at 26 °C, and relative humidity of 70% (according to French standard NF-414)

- protection class: **IP 24**
- refrigerant gas: **R410A**
- refrigerant charge: see product information plate
- class: I,
- degree of pollution: 2,
- overvoltage category: II

## 2. Installation



Do not take grip on the outer casing to pick up the device, hold the base.

### 2.1 Access to the technical compartment

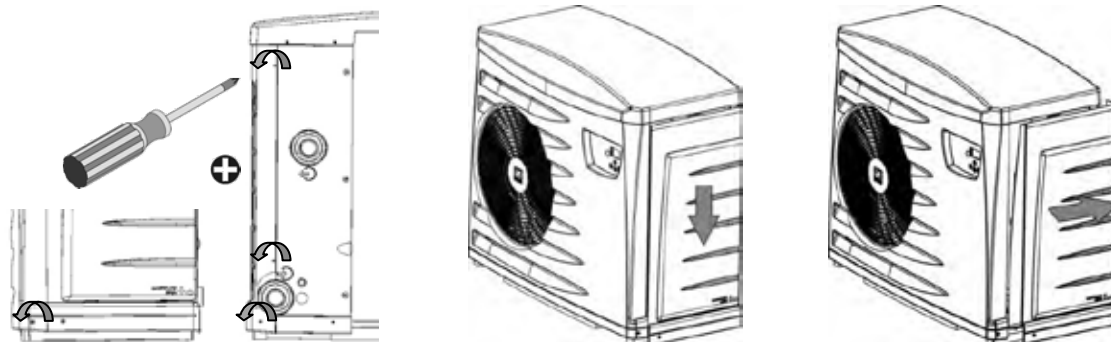

### 2.2 Selecting an installation site



The device must be installed outdoors and there must be adequate open space surrounding it (see §2.4).

- **the heat pump must be installed** at a certain distance from the pool so as to avoid exposure to water splashes. The appropriate distance should be defined according to the national electrical standards that apply in the country of installation (for France: 3.5 meters).
- **the heat pump must not be installed:**
  - near a source of heat or inflammable gas,
  - near a road/passage where there is a risk of water and mud splashes,
  - facing a strong wind,
  - with the vent facing toward a permanent or temporary obstacle (window, wall, hedge, etc...), it must be at least 4 meters from any potential obstacle.

## 2.3 Installing the device

- place on a stable, solid (concrete slab type), level and plane surface,
- ensure that it will not be flooded by condensation water produced by the device during operation (see §2.4)

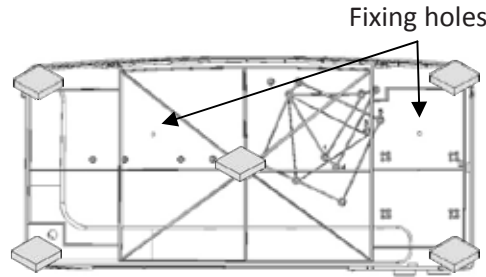



**i** The anti-vibration blocs are fitted under the base of the heat pump.  
 The heat pump can be fixed to the ground using the brackets at the base of the unit (attachments not included). A diagram for drilling is featured on the back of the packing box.

## 2.4 Hydraulic connections

**⚠** Check the direction of the pipework connection (see § “Dimensions” in the appendix).

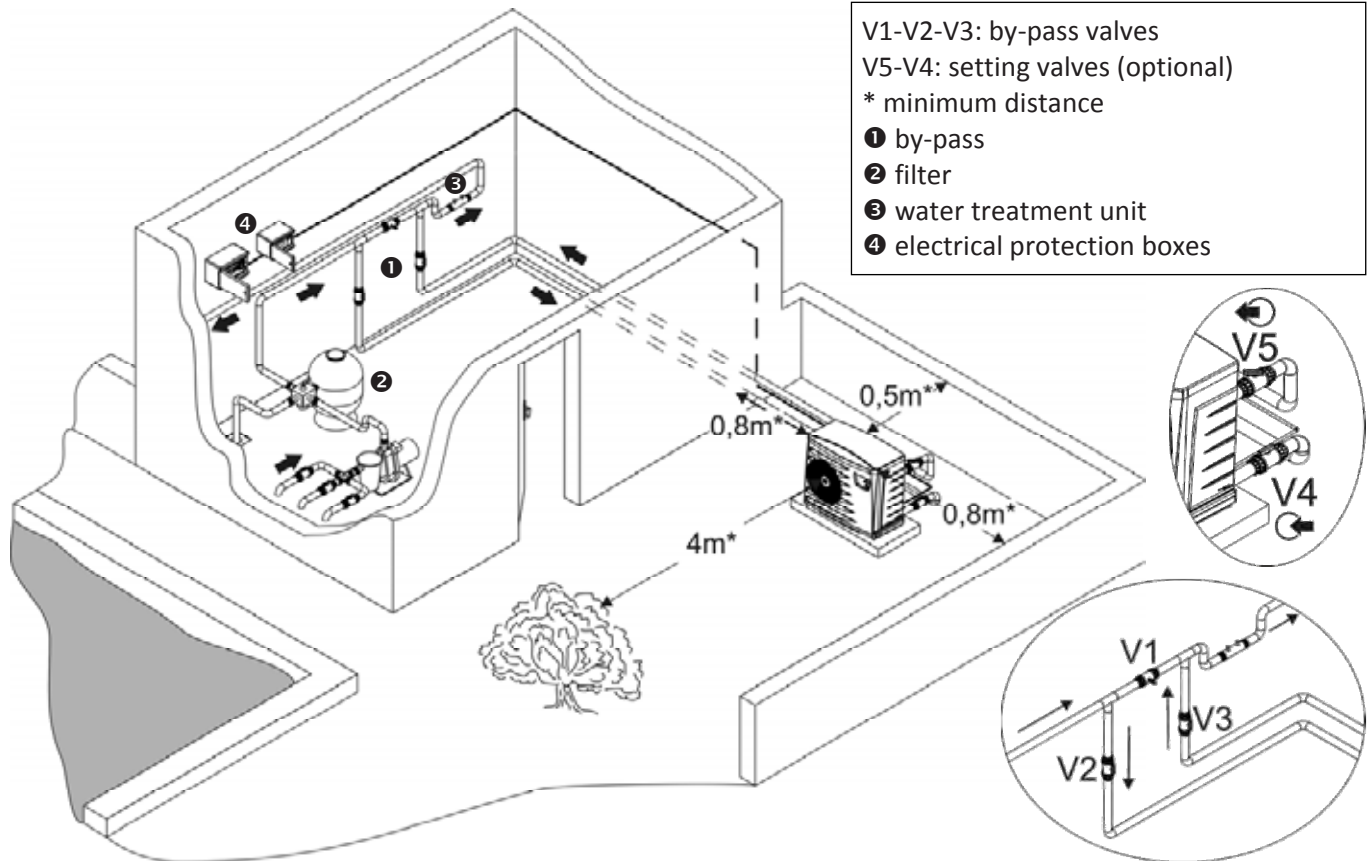
- The connection include a  $\varnothing 50$  PVC rigid pipe, from a by-pass, on the swimming pool filtration circuit, after the filter ② and before any water treatment unit ③.
- check the tightening of the hydraulic connections, and check for leaks,



Z300	Hydraulic circuit pressure		Connections  = inlet  = outlet	Mean water flowrate m <sup>3</sup> /h	Head loss test mCE
	test bar	service bar			
M4	3	1.5	Ø50	4	1.4
M5-T5- MD5-TD5				5	1.5
M7				6	1.5
MD8-TD8				6.5	1.1

Disposing of condensation:

Warning: your device can produce several litres of water per day. It is strongly recommended to guide the flow to drains.

- connect a Ø18 interior pipe (not supplied), to the grooved end-piece mounted on the base of the appliance,

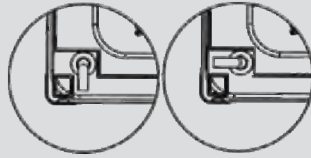

- outlet: to the back or on the side:

## 2.5 Electrical connections

### 2.5.1 Voltage and protection

- the electrical supply to the heat pump must include a protection and circuit-breaker device (not supplied) complying with the standards and regulations in force in the country,
- additional protection may be required during installation to protect against overvoltage category II,
- the device is designed for connection to a general power grid with TT and TN.S grounding systems,
- electrical protection: circuit-breaker (curve D) or fuse (Am) (see § 2.5.3 for ratings), and with a 30 mA dedicated differential trip switch (circuit-breaker or switch).



- electrical conduits must be secured,
- tolerance for voltage variation:  $\pm 6\%$  (during operation),
- use cable suitable for outdoor use, type RO2V or equivalent in countries outside of the European community, with an outer diameter between 9 and 18 mm,
- use the cable gland to run the supply cable into the device.

### 2.5.2 Connections

- the electrical supply cable must not be exposed to elements that are sharp, hot or at risk of being crushed,
- check that all cables are secure and all terminal connections are correct.

**Loose terminals may cause the supply terminal board to overheat and will void the warranty.**

**The device must be connected to the earth (grounded)**



**Risk of electric shock inside the device**

**The device must only be commissioned by a qualified and experienced technician**

**If the power cable is damaged, it must be replaced by a qualified technician**

#### Single-phase

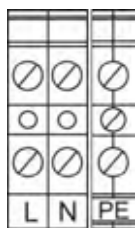

phase (L) + neutral (N) + Earth (PE)

#### Three-phase

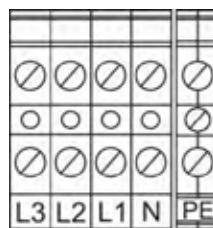

phases (L1 + L2 + L3) + neutral (N)  
+ Earth (PE)

### 2.5.3 Cable cross-sections

- supply cable cross-section: cables with a maximum length of 20 metres (calculation base:  $5A/\text{mm}^2$ ), must be checked and adapted depending on installation conditions.

Z300	Voltage	Maximum I input		Cable cross-section		Electrical protection
		A		mm <sup>2</sup>		A
M4	230V-50Hz	10		3 x 2.5	3G2.5	16
M6-MD6	230V-50Hz	14.5		3 x 2.5	3G2.5	16
T6-TD6	400V-50Hz	5		5 x 2.5	5G2.5	10
M7	230V-50Hz	16.1		3 x 4	3G4	20
MD8	230V-50Hz	22		3 x 6	3G6	25
TD8	400V-50Hz	9.4		5 x 2.5	5G2.5	10

## 2.5.4 Connection of options

- use cables with a cross-section: of  $2 \times 0.75 \text{ mm}^2$  or larger, of type RO2V or equivalent in countries outside of the European Community, with an outer diameter of between 8 and 13 mm.

 Remove the lid (just above the cable gland) and fit the supplied cable glands to run the cables into the device. The cables used for the optional features and the power supply must be held together using a collar inside the device, just after the cable gland.

 **Any incorrect connection to terminals 1 to 8 could damage the regulator and void the warranty.**  
**Never supply the motor of the filter pump directly using terminals 1-2.**  
**If orange terminals 1 to 8 are serviced, back current may exist.**

- "heating priority"









- Function: servo function to control the filtration pump operation (by a minimum 5-minute cycle every hour, with filtration maintained if the pool temperature is below the required temperature),
- thanks to a dry contact (without max. I polarity = 8 A)
- between terminals 1-2,

- alarm

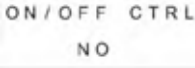
- Function: connect a relay to the alarm terminal,
- thanks to a dry contact (without max. I polarity = 2 A)
- between terminals 5-6,

- remote on/off control

- Function: connect a remote "start/stop" button
- thanks to a zero-potential free contact, without 230 V - 50 Hz polarity, connect the cable to the busbar between terminals 7-8,

- activate the command by pressing  for 5 seconds when regulation is not on standby:   
 then , then press 3 seconds on  : , select "Yes" using key , then  
 validate by pressing  : , press  to exit.

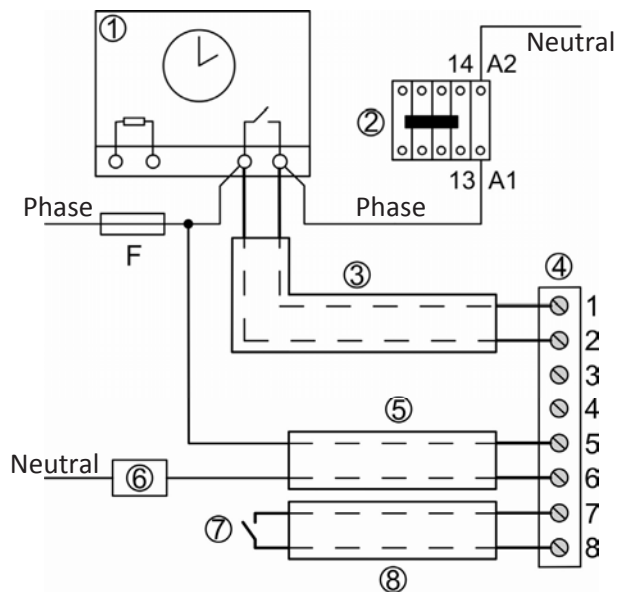

- ① filter timer
- ② power contactor (3-pole or 2-pole), supplying the filter pump
- A1-A2: supply to the power contactor coil of the filter pump
- ③ independent connecting cable for the "heating priority" function
- ④ terminal
- ⑤ independent connecting cable for alarm contact relay
- ⑥ alarm contact relay
- ⑦ remote on/off switch
- ⑧ independent connecting cable for remote on/off control

- remote control unit

- Function: control the heat pump remotely,
- refer to the instructions for the remote control unit for connections.

### 3. Use

#### 3.1 Presentation of the regulation



Symbol	Designation	steady	flashing
	water flow	water flow-rate ok	water flow too weak, high or absent
	ambient air temperature	adequate	inadequate
	operation indicator	During heating or air conditioning	On standby until operating command received
	defrost indicator	Defrost in progress	/
	On/off button		
	button to set and confirm parameters		
	value setting buttons		

##### 3.1.1 Reading and changing parameters

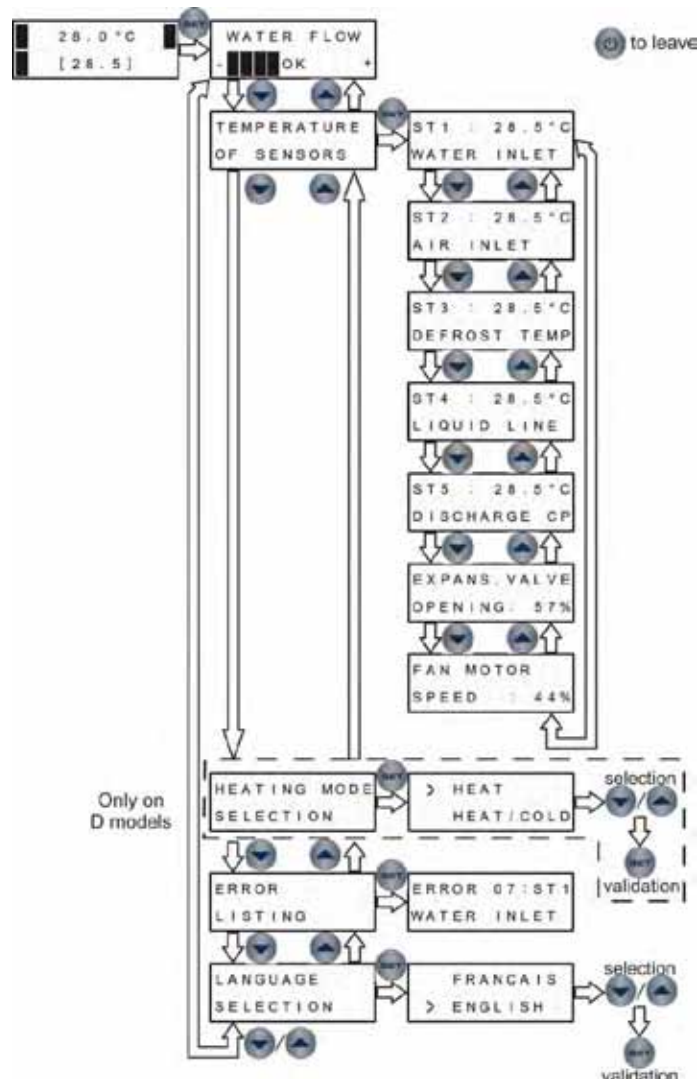



### 3.1.2 Locking and releasing the key pad

Press  and  for 3 seconds:  or 

### 3.2 Starting the device





- check that no tools or other objects have been left inside the device,
- the access door for technical components must be fitted,
- set the by-pass and setting valves (see § 2.4) as follows:
  - valve 1 completely open,
  - valves 2-3-4 & 5 closed.

 **An incorrect setting of the by-pass valve may lead to device malfunction**

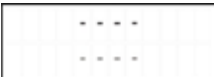

- switch on the filter system,
- progressively close valve 1 in order to increase the filter pressure to 150 g (0.150 bar) ,
- open valves 2, 3 and 4 completely, then half open valve 5 (see §2.4) (the air accumulated in the heat pump condenser and in the filter circuit is then bled),

 If valves 4 and 5 are not fitted, open valve 1 completely, and half close valve 3.



- power-up the heat pump,







• if the heat pump is on stand-by: , press on  for 3 seconds,  will appear for 2 seconds, and  (die Softnummer hängt von dem Modell ab) for 3 seconds, and the water

and set-point temperatures will be displayed: , a 2-minute delay will start,

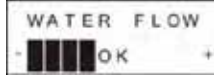
- set the required water temperature:
  - press  to increase temperature,
  - press  to decrease temperature,

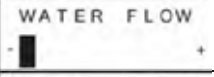
 When the pool reaches the required temperature, the heat pump will automatically stop.

- set the water flow-rate using the menu  is steady: press  to display the water flow-rate status:

Status	water flow-rate ok	no water flow	water flow-rate too weak	water flow-rate too strong
Display				
				

- set the flow-rate using valve 5 (or 3 if no valve 5 is fitted), and, to quit the menu, press .

 **During this adjustment phase, wait for a few minutes after each change in valve position to allow the device to balance.**

### 3.3 Checks to perform after start-up

The heat pump must stop when:

- the set-point temperature is lowered using the digital control panel,
- filtering is stopped or valve 2 or 3 is closed 3,
- the digital control panel is turned off by pressing .

### 3.4 Winter storage



**Winter storage is essential due to the risk of the condenser freezing and breaking. This situation is not covered by the warranty.**

**To avoid damaging the device with condensation, do not cover it with an air-tight cover.**

- switch the digital control panel to "stand-by" mode by pressing  for 3 seconds, and cut the power supply,
- open valve 1,
- close valves 2 and 3, and open valves 4 and 5 (if fitted),
- ensure that no water is flowing through the heat pump,
- drain the water condenser by unscrewing the two pool water inlet and outlet connections at the back of the heat pump,
- in the case of full winter storage conditions for the pool: re-connect the inlet and outlet connections to avoid foreign bodies entering into the condenser,
- in the case of winter storage for the heat pump alone: do not reconnect the inlet and outlet connectors, instead place two plugs (supplied) on the condenser water inlet and outlet.
- cover the heat pump with a micro-breathing overwintering cover (optional accessory, see §4.3).

## 4. Maintenance

### 4.1 Maintenance instructions



It is recommended that the device be general serviced on a yearly basis to ensure proper operation, maintain performance levels and prevent some potential failures.

**This is the responsibility of the user and must be performed by a qualified technician.**

**Do not use a high-pressure water hose.**

- ensure no foreign bodies obstruct the fan grid.
- clean the evaporator with a soft brush and a fresh water jet (disconnect the power cable), do not twist or bend the metal blades, then to clean the discharge pipe of the condensates in order to evacuate the impurities which could block it,
- clean the outside of the unit with a solvent-free product. A specific PAC NET cleaning kit is available as an optional extra (see §4.3),
- check that the water condensation flows out properly during the operation of the device.
- check the proper operation of the regulator,
- check electrical components,
- check that all metal elements are grounded,
- check the tightening and connections of electric cables and the cleanliness of the electrical compartment.

### 4.2 Additional recommendations

**in relation to the Pressure Equipment Directive (PED-97/23/CE)**

#### 4.2.1 Installation and maintenance

- the unit may not be installed close to combustible materials, or the air duct inlet of an adjacent building .
- with some devices, it is essential to fit protection grids if the unit is installed in an area with uncontrolled access.
- during installation, troubleshooting and maintenance, pipes may not be used as steps: the pipe could break under the weight, spilling refrigerant and possibly causing serious burns.
- when servicing the appliance, the composition and state of heat carrying fluid must be checked, as well as the absence of any refrigerant.
- during the annual unit sealing test in accordance with applicable legislation, the high and low pressure switches must be checked to ensure that they are securely fastened to the coolant circuit and that they cutoff the electrical circuit when tripped.
- during maintenance work, ensure there are no traces of corrosion or oil around cooling components.
- before beginning work on the cooling circuit, stop the device and wait for a few minutes before fitting the temperature and pressure sensors. Some elements such as the compressor and piping may reach temperatures in excess of 100°C and high pressures with the consequent risk of severe scalding.

## 4.2.2 Troubleshooting

- all soldering work must be carried out by a someone qualified to do so.
- replacement pipes must always be made of copper in compliance with standard NF EN 12735-1.
- leak detection; pressure test:
  - never use oxygen or dry air, risk of fire or explosion,
  - use dry nitrogen or the mixture of nitrogen and refrigerant indicated on the information plate,
  - the test pressure for both the high and low pressure circuits must not exceed 42 bar.
- the high pressure circuit pipes are made of copper and have a diameter equal to or greater than 1"5/8. A certificate as indicated in §2.1 in compliance with standard NF EN 10204 will be requested from the supplier and filed in installation technical documentation.
- technical data relative to the safety requirements of the various applicable directives must be indicated on the information plate.
- **This data must be recorded in the installation instructions for the device which are included in the installation technical file: model, code, serial number, maximum and minimum OT, OP, year of manufacture, EC label, manufacturer's address, refrigerant and weight, electrical parameters, thermo-dynamic and acoustic performances.**

## 4.3 Available accessories

Name	PAC NET	Wintering cover	Remote control unit	Technical room kit
Representation				

## 4.4 Recycling











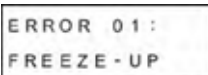







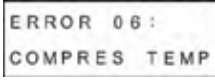

This symbol means that your device must not be thrown in the bin. The device must be collected by a selective system in view of re-use, recycling or similar. Any substances it may contain which are potentially dangerous to the environment shall be eliminated or neutralised.

Request information on recycling procedures from your retailer.

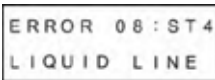
## 5. Troubleshooting

### 5.1 Display of the regulator

Display	Designation	Cause	Solution	Reset
	Protection of heat exchanger in cold mode	Temperature of ST4 sensor too low	Wait for the surrounding temperature to become warmer	Automatic
	High temperature defect for the evaporator in "cooling" mode	Temperature probe ST3 above 60°C or evaporator scaled up	Clean the evaporator, if the defect persists, contact an approved technician	Automatic if temperature probe ST3 is below 45°C
	Phase order defect (only on three-phased models)	1. wiring incorrect on the supply terminal board of the device, 2. modification of phase order by electrical supplier, 3. temporary failure of one or several phases	1. reverse the phases on the supply terminal board (without power to the device) 2, 3, 4. contact your electricity provider to find out if modifications have been made to your equipment.	Switch the power supply off or press 

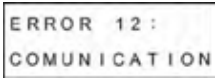
Display	Designation	Cause	Solution	Reset
	Refrigerant circuit low pressure defect	Low pressure circuit pressure defect (if the defect remains after reset)	Contact an approved technician	Automatic reset (for less than 4 defects per hour) or press 
	Refrigerant circuit high pressure defect	<ol style="list-style-type: none"> <li>1. water and air mixture passing in the appliance,</li> <li>2. unsatisfactory water flow,</li> <li>3. blocked flow controller</li> <li>4. clogged or blocked heat exchanger</li> </ol>	<ol style="list-style-type: none"> <li>1. check the pool hydraulic circuit</li> <li>2. increase the flow-rate using the by-pass, check that the pool filter is not clogged)</li> <li>3. check the flow-rate controller</li> <li>4. clean the exchanger</li> <li>5. if the defect persists, contact an approved technician</li> </ol>	Automatic reset (for less than 4 defects per hour) or press 
	Compressor discharge temperature defect	Compressor discharge temperature too high	contact an approved technician	press  for 3 seconds
	Control sensor defect (ST1)	Sensor out-of-order or disconnected (connector J2 red on plate A1)	Replace or reconnect the sensor	Switch the power supply off or press 
	Water flow-rate sensor defect (ST4)	Sensor out-of-order or disconnected (connector J8 white on plate A1)	Replace or reconnect the sensor	Switch the power supply off or automatic reset if the defect disappears
	Defrost sensor defect (ST3)	Sensor out-of-order or disconnected (terminals 1-2 of connector J3 white on plate A2)	Replace or reconnect the sensor	Switch the power supply off or press 
	Anti-freeze sensor defect (ST2)	Sensor out-of-order or disconnected (terminals 3-4 of connector J3 white on plate A2)	Replace or reconnect the sensor	Switch the power supply off or press 
	Compressor discharge sensor defect (ST5)	Sensor out-of-order or disconnected (connector J7 black on plate A1)	Replace or reconnect the sensor	Switch the power supply off or automatic reset if the defect disappears.
	Communication s' defect between the main card A1 and the display card A2	<ol style="list-style-type: none"> <li>1. Incorrect connection between plates A1 and A2</li> <li>2. Card supply defect</li> <li>3. Cards out of order</li> </ol>	<ol style="list-style-type: none"> <li>1 and 2. Check connections (connectors J8 and J9 yellow, and J7 and J4-J5 black)</li> <li>1, 2 and 3. if the defect persists, contact an approved technician</li> </ol>	Switch the power supply off or automatic reset if the defect disappears

## 5.2 Solving device malfunctions

Dysfunction	Causes	Verification / solution
The device is not operational	No display	Check the supply voltage and the fuse F1
	The pool temperature is above the set-point temperature	Increase the set-point temperature
	A message is displayed on the screen	Check the meaning of message §5.1
	Absent or inadequate water flow-rate	Check the water flow-rate (by-pass, filtration)
The device is operational, but water temperature fails to rise	Inadequate filtering time	Set the filtering system to manual 24- hour operation for temperature control
	Non-compliant period of use	Check that outdoor temperature is within the operating range (see §1.3)
	The heat pump is under-dimensioned	Check the characteristics of the heat pump according to the pool
	The automatic pool water filler is blocked in the open position	Check the correct operation of the automatic filler
	The heat insulating cover is not used	Fit the heat insulating cover
	The evaporator is clogged	Clean the evaporator (see §4.1)
	The device is incorrectly installed	The device must be installed outdoors. Check that there is no obstacle less than 4 metres from where the blower is facing, and 0.50 metres behind the heat pump.
	A message is displayed on the screen	Check the meaning of message §5.1
The fan is turning, but the compressor stops from time to time without an error message appearing	The heat pump does defrost cycles from time to time	This is normal if the outdoor temperature is below 10 °C
	The evaporator is clogged	Clean the evaporator (see §4.1)
the heat pump makes trip the circuit breaker	The circuit breaker rating is too low or inappropriate	Check the circuit breaker (see § 2.5.3).
	The cable cross-section is too small	Check the cable cross-section (see § 2.5.3)
	The supply voltage is too low	Call your electricity provider
	Voltage drops when the compressor is powered on	Add a soft starter for models M5, MD5 and M7
	Varistor(s) VA1 and/or VA2 is/are out of order	Replace the varistor(s)

## 5.3 FAQ

<b>Is it possible to improve temperature performance?</b>	In order to improve the efficiency of your heat pump it is recommended that you:	protect the pool with a cover (floating cover, roller cover, etc.), to avoid heat loss
		choose periods when the outside temperature is warm (on average > 10° C) in order to facilitate the temperature increase (this may take several days. The actual time will vary according to weather conditions and the power of the heat pump)
		the higher the ambient air temperature, the more efficient the heat pump will be
		keep the evaporator clean
	Check that filtration time is sufficient	during the heating phase, water flow must be continuous (24/24)
	to maintain the temperature throughout the season, allow for “automatic” flow of at least 12 hours/day (the longer automatic flow is used, the more time the heat pump will have to function and to heat the water)	
	Setting the set-point to maximum will not heat the water any faster	

<b>Why is my heat pump not heating?</b>	on start-up the device remains on “pause” for 3 minutes before actually starting up: check that this period has passed
	once the pool has reached the set-point temperature, the heat pump switches off: check that the water temperature is lower than the requested temperature (see §3.2)
	if the water flow-rate is zero or inadequate, the heat pump will stop: check that water is flowing correctly through the heat pump, and check the hydraulic connections
	when the outdoor air temperature drops below 5 or -8 °C, the heat pump will stop: check the outdoor temperature
	the heat pump may have detected a malfunction: check if an error code is displayed on the screen, if so refer to §5.1
	If the problem persists after you have checked all of the above points: contact your installer
<b>Where should my water treatment system be positioned with respect to the heating system?</b>	The water treatment system (chlorinator, salt chlorinator, etc.) must be installed preferably downstream from the heat pump (see installation §2.4), and must be compatible with the latter (check with the manufacturer)
<b>The heat pump is giving off water: is this normal?</b>	Your heat pump will give off water in the form of condensation. This water is the humidity contained in the air, which condenses on contact with certain cold components inside the heat pump. Note: your device can produce several litres of water per day.

## 6. Product registration

Register your product using our website:

- you will be among the first to be informed of new Zodiac products and special offers,
- You can help us to constantly improve our product quality.

Australia – New Zealand	<a href="http://www.zodiac.com.au">www.zodiac.com.au</a>
Europe, South Africa and rest of the world	<a href="http://www.zodiac-poolcare.com">www.zodiac-poolcare.com</a>



### **Rainbow Pool Products**

PO Box 2388, Mansfield Qld 4122

Telephone STD 61-7-3849 5385

Facsimile STD 61-7-3849 5384

Email: [info@rainbowpoolproducts.com.au](mailto:info@rainbowpoolproducts.com.au)

Web: [www.rainbowpoolproducts.com.au](http://www.rainbowpoolproducts.com.au)

# Schéma électrique

## Z300 M4-M5-M7

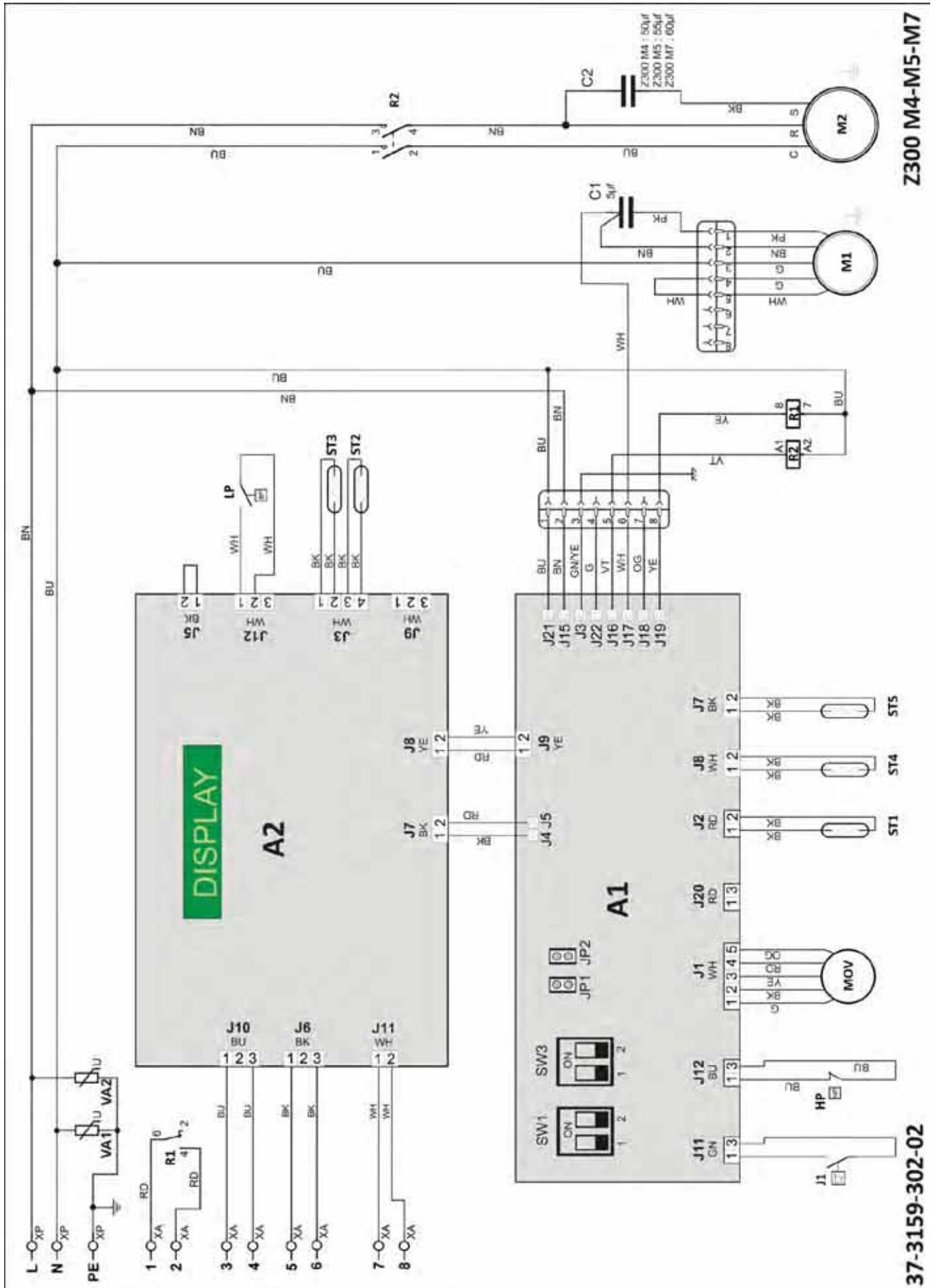

Z300 M4-M5-M7

37-3159-302-02

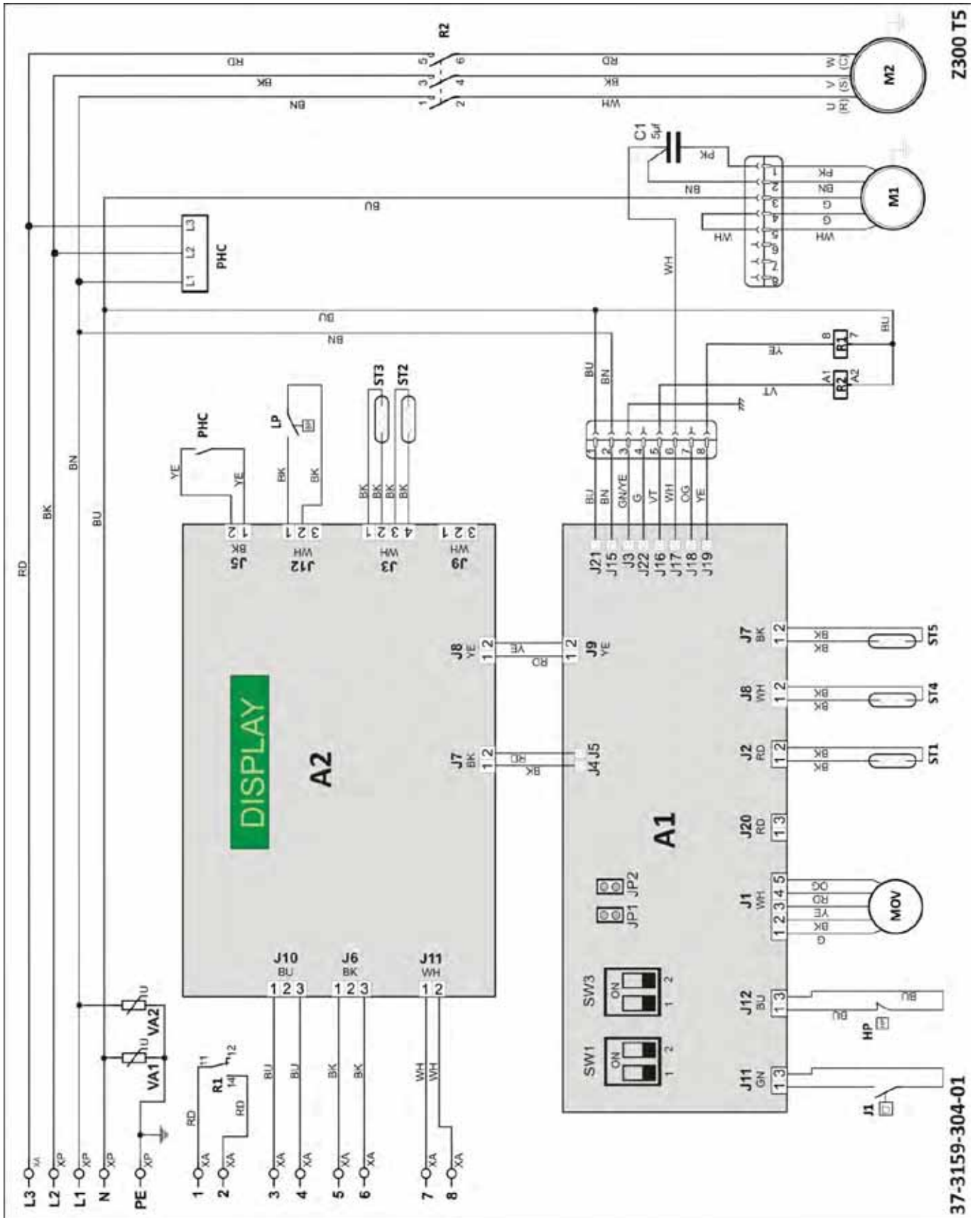

Z300 T5

37-3159-304-01



# Z300 MD5

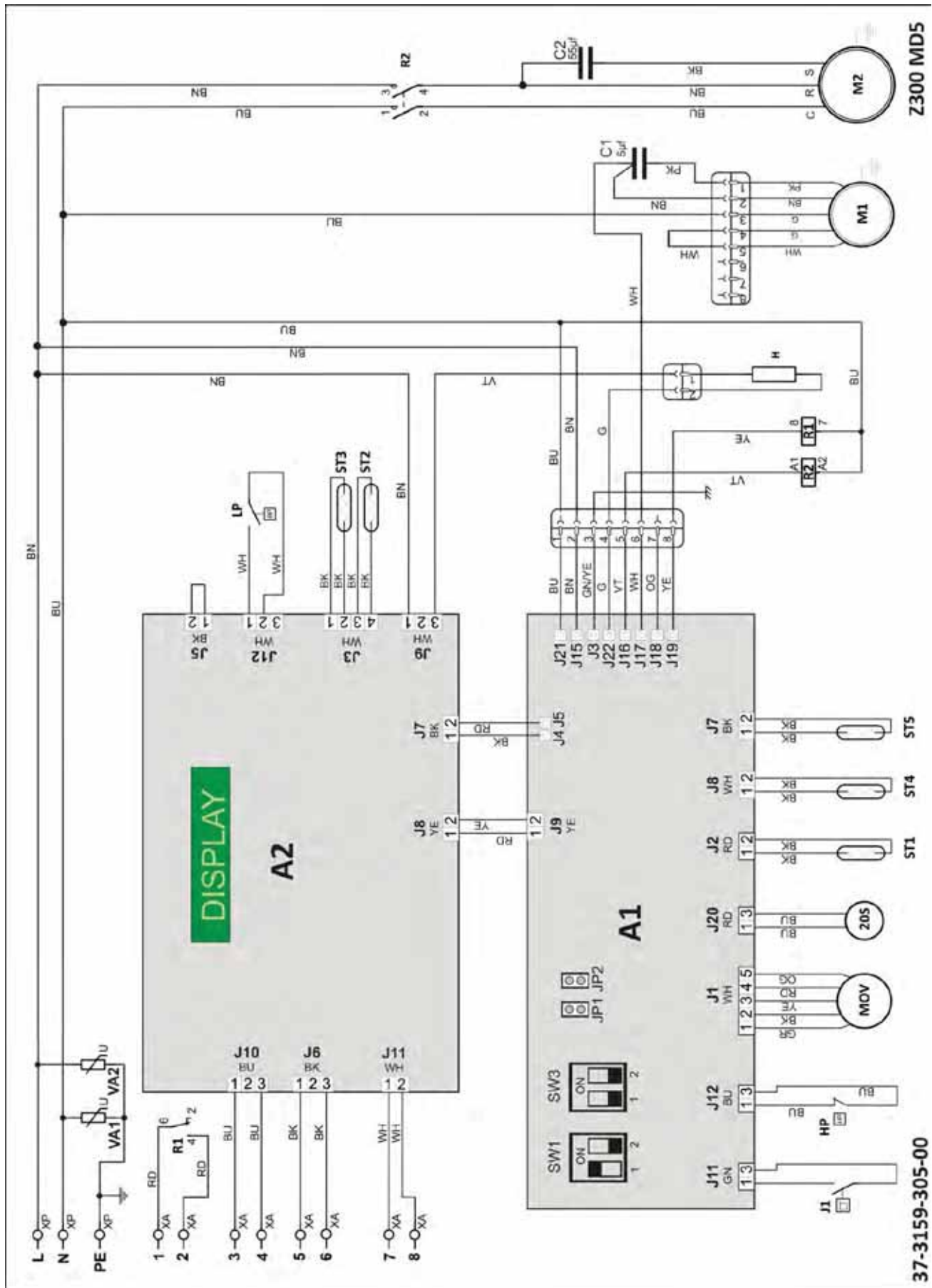

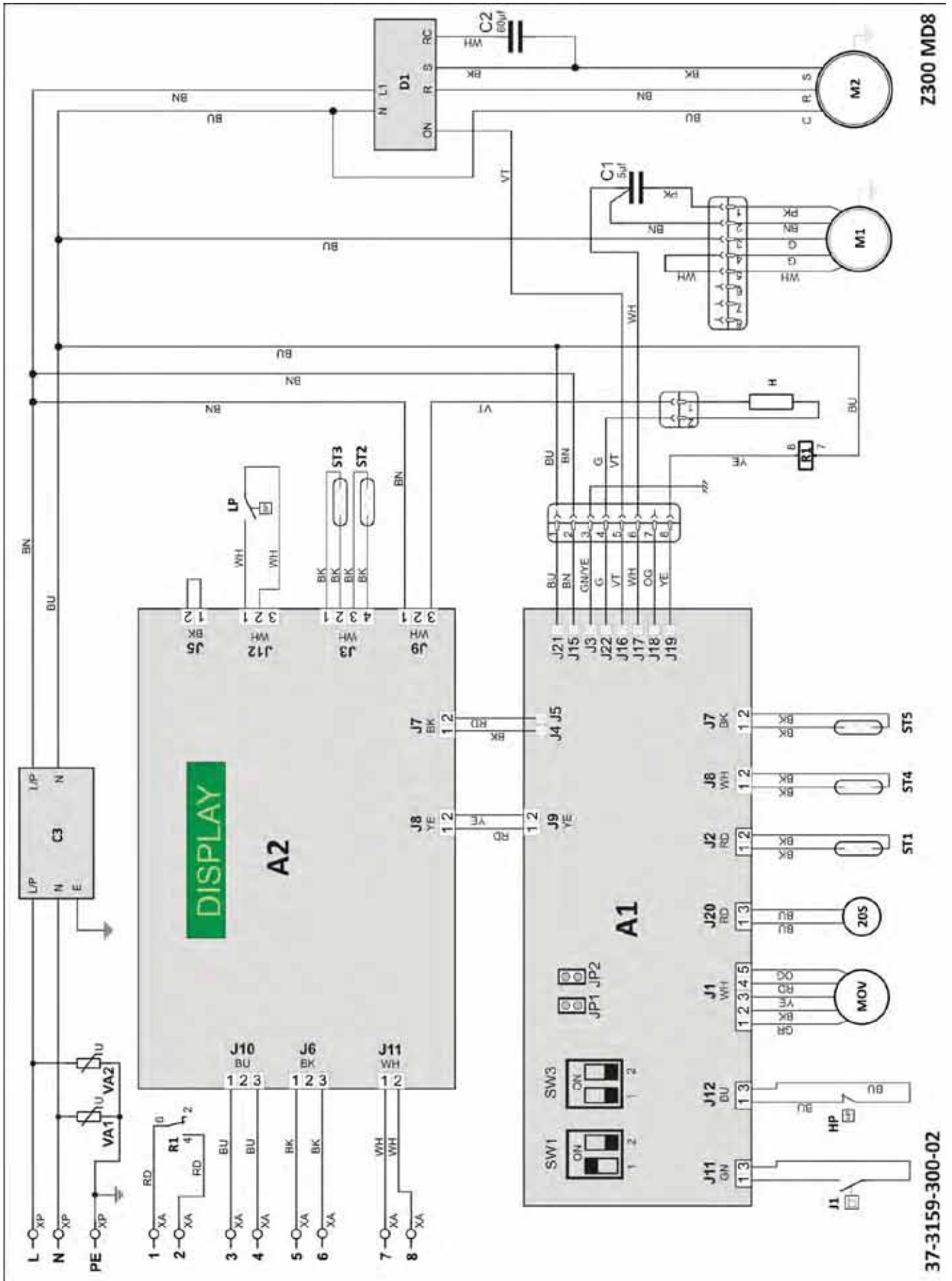

Z300 MD8

37-3159-300-02

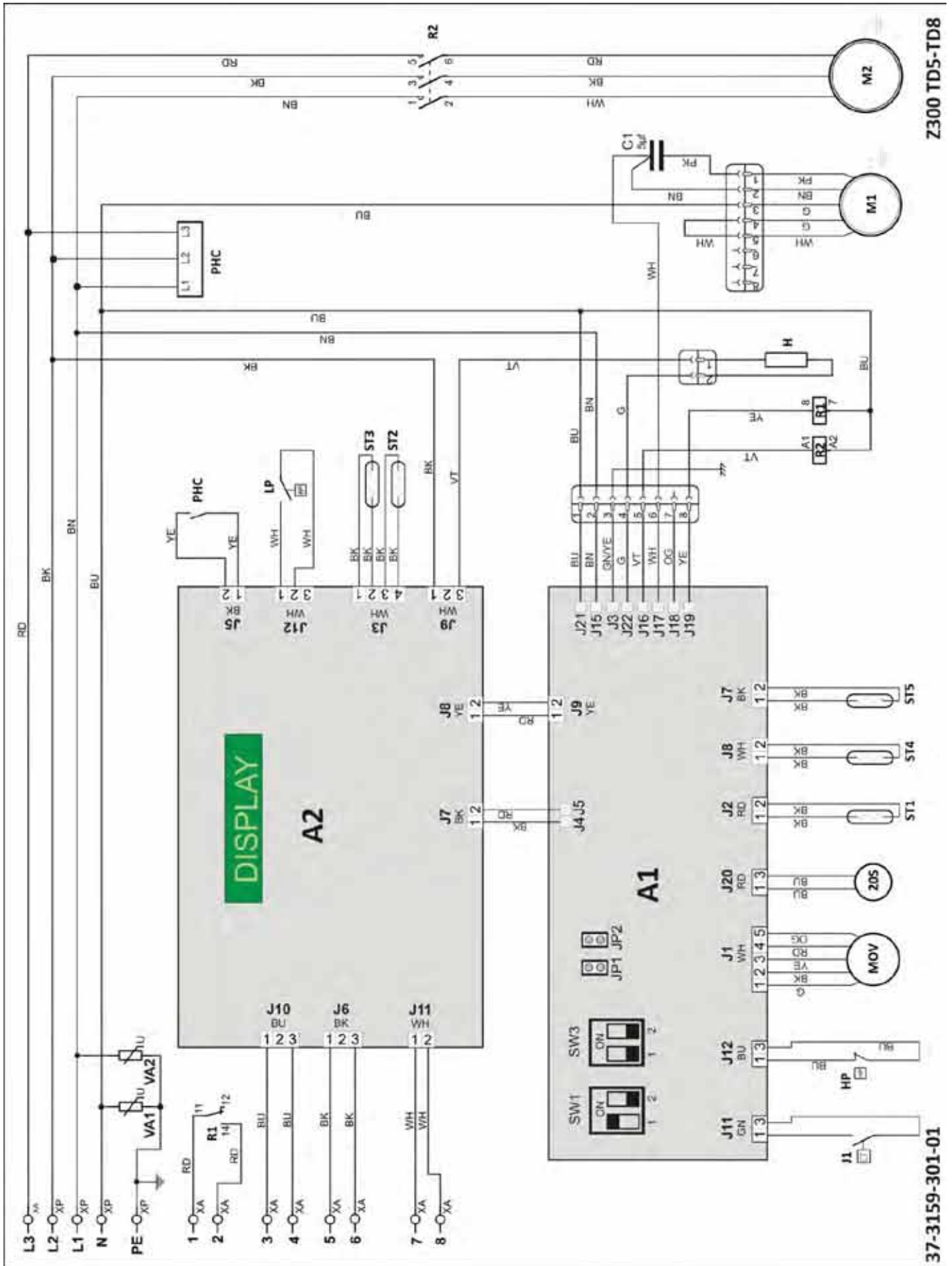

Z300 TD5-TD8

37-3159-301-01

<b>L-N-PE</b>	Alimentation (230V-1N-50Hz)
<b>L1-L2-L3-N-PE</b>	Alimentation (400V/3N/50Hz)
<b>PE</b> (⏚)	Terre
<b>1-2</b>	Commande pompe (contact 8A maximum)
<b>3-4</b>	Commande réchauffeur électrique (contact 2A maximum)
<b>5-6</b>	Commande alarme (contact 2A maximum)
<b>7-8</b>	Commande à distance
<b>20S</b>	Bobine vanne 4 voies
<b>A1</b>	Carte électronique de régulation
<b>A2</b>	Carte électronique d'affichage
<b>C1</b>	Condensateur ventilateur
<b>C2</b>	Condensateur compresseur
<b>C3</b>	filtre
<b>D1</b>	Démarrreur progressif
<b>H</b>	Résistance dégivrage
<b>HP</b>	Pressostat haute pression
<b>LP</b>	Pressostat basse pression
<b>J1</b>	Interrupteur de débit
<b>M1</b>	Moteur ventilateur
<b>M2</b>	Moteur compresseur
<b>MOV</b>	Détendeur
<b>PHC</b>	Contrôleur d'ordre de phase
<b>R1-R2</b>	Contacteur
<b>ST1</b>	Sonde de régulation
<b>ST2</b>	Sonde anti-gel
<b>ST3</b>	Sonde de dégivrage
<b>ST4</b>	Sonde ligne liquide
<b>ST5</b>	Sonde refoulement compresseur
<b>VA1-VA2</b>	varistance
<b>BK</b>	Noir
<b>BN</b>	Marron
<b>BU</b>	Bleu
<b>G</b>	Gris
<b>GN/YE</b>	Vert/jaune
<b>PK</b>	rose
<b>OG</b>	Orange
<b>RD</b>	Rouge
<b>VT</b>	Violet
<b>WH</b>	Blanc
<b>YE</b>	Jaune



## Rainbow Pool Products

PO Box 2388, Mansfield Qld 4122

Telephone STD 61-7-3849 5385

Facsimile STD 61-7-3849 5384

Email: [info@rainbowpoolproducts.com.au](mailto:info@rainbowpoolproducts.com.au)

Web: [www.rainbowpoolproducts.com.au](http://www.rainbowpoolproducts.com.au)

## Dimensions et description

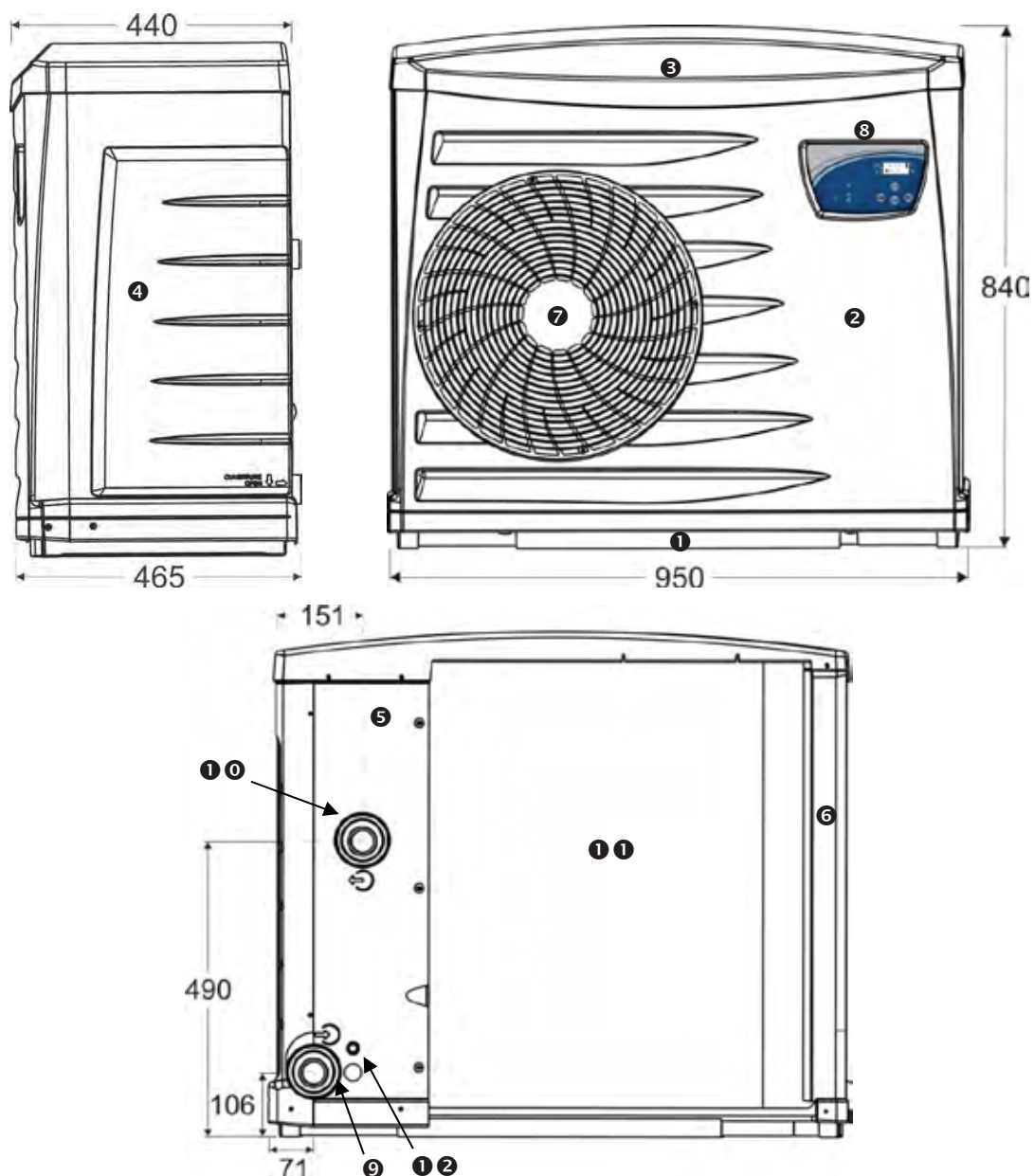

<b>1</b>	Base
<b>2</b>	Façade
<b>3</b>	Capot
<b>4</b>	Porte technique
<b>5</b>	Panneau arrière
<b>6</b>	Montant
<b>7</b>	Grille
<b>8</b>	Régulateur
<b>9</b>	Entré d'eau de piscine Ø1" ½
<b>10</b>	Sortie d'eau de piscine Ø1" ½
<b>11</b>	Evaporateur
<b>12</b>	Presse-étoupe

Z300	Poids (Kg)
M4	52
M5-T5-MD5-TD5	63
M7	68
MD8-TD8	81